

REVISIONS					
ECO NO.	REV	DESCRIPTION	DATE	DRAFT	APPRV
1600027	0	NEW RELEASE	04/28/2015	CD	MJ

NOTES:

1. DEPTH COVER TO BACK: 26.38 [670.1]
2. APPROXIMATE WEIGHT PER STACK:
6 HIGH: 1968 lbs [894 kg]
3. USE M6 X 25 BOLTS IN ALL POSTS
UNLESS OTHERWISE NOTED.
4. TERMINAL PLATE ASSEMBLIES WILL ADD
TO OVERALL DIMENSIONS; CONSULT I&O
MANUAL FOR DETAILS.

4	L06-411288-06013	CABLE ASSY 500MCM 60"		16
720	W02-062501	BOLT M6 X 25 A2	NOT SHOWN	15
720	W03-0601	WASHER M6 X 6.4 17.0 3.0 A2	NOT SHOWN	14
20	K17-TPCOV813A	KIT COVER AGP-13 TOP ASSY CLEAR		13
100	K17-ISCOV813A	KIT COVER AGP-13 STD ASSY CLEAR		12
1	K17-418293	KIT 1-120 NUMERALS & GREASE	NOT SHOWN	11
18	K17-417001	KIT TIE PLATE MECH STACK/STACK		10
100	K17-417000	KIT HARDWARE MECH INTERMOD		9
20	K17-417030	KIT HORIZONTAL SUPPORT		8
3	K17-417003LP	KIT TERMINAL PLATE STANDARD		7
1	K17-400403	KIT AGP ACCESSORY	NOT SHOWN	6
6	L03-420127-001	CONNECTOR 2.00 X .12		5
72	L03-420110-009	CONNECTOR 2.00 X .12		4
72	L03-411730-002	CONNECTOR 2.00 X .12		3
243	L03-109209-010	CONNECTOR 1.00 X .06		2
120	M52-110039 (M53-110039)	001AGP 10039W		1
X	M87-120-10039-206BMM(V)	120-100G39 MEDIUM		X
QTY	PART OR IDENT NO.	NOMENCLATURE OR DESCRIPTION	REMARKS	ITEM

PARTS LIST

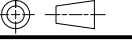
UNLESS OTHERWISE SPECIFIED DIMENSIONS ARE IN INCHES TOLERANCES ARE: DECIMALS [MM] FRACTIONAL ANGLE .X± X± .XX± 0.X± ± ± .XXX± 0.XX± DO NOT SCALE DRAWING		THE USE OF INFORMATION CONTAINED HEREIN IS RESTRICTED FOR THE BENEFIT OF GNB ONLY. UNAUTHORIZED USE OR DISCLOSURE, COPYING OR OTHERWISE REPRODUCING (IN ANY MANNER) ANY PORTION OF THIS DRAWING WITHOUT PRIOR WRITTEN PERMISSION OF AN AUTHORIZED OFFICIAL OF GNB, IS PROHIBITED.		 3950 SUSSEX AVENUE AURORA, IL 60504-7932 USA	
MATERIAL: V-0 SYSTEM DENOTED BY ()		DRAWN C. DANNER DATE 04/28/2015	TITLE 120 CELL ABSOLYTE 100G39 (V-0) 20 STACKS / 6 HIGH 60 - 179 MINUTES BACKUP TO 1.75 VPC		
PROCESS:		CHECK C. DANNER DATE 04/28/2015	DESIGN C. DANNER DATE 04/28/2015	SIZE B	CAGE CODE 88219
REMOVE ALL BURRS AND BREAK SHARP EDGES		THIRD ANGLE PROJECTION 	CAD REFERENCE CREATED WITH AC	DRAWING NO. 440429	REV 0
		SCALE: -		THIS DWG. SUPERCEDES	
		DIMENSIONS IN [] ARE MILLIMETERS		SHEET 1 OF 2	

Z66-440429	AA
M87-120-10039-206BMMV	AA
M87-120-10039-206BMM	AA
PART NUMBER	PART REV

REVISIONS				
ECO NO.	REV	DESCRIPTION	DATE	DRAFT APPRV
1600027	0	NEW RELEASE	04/28/2015	CD MJ

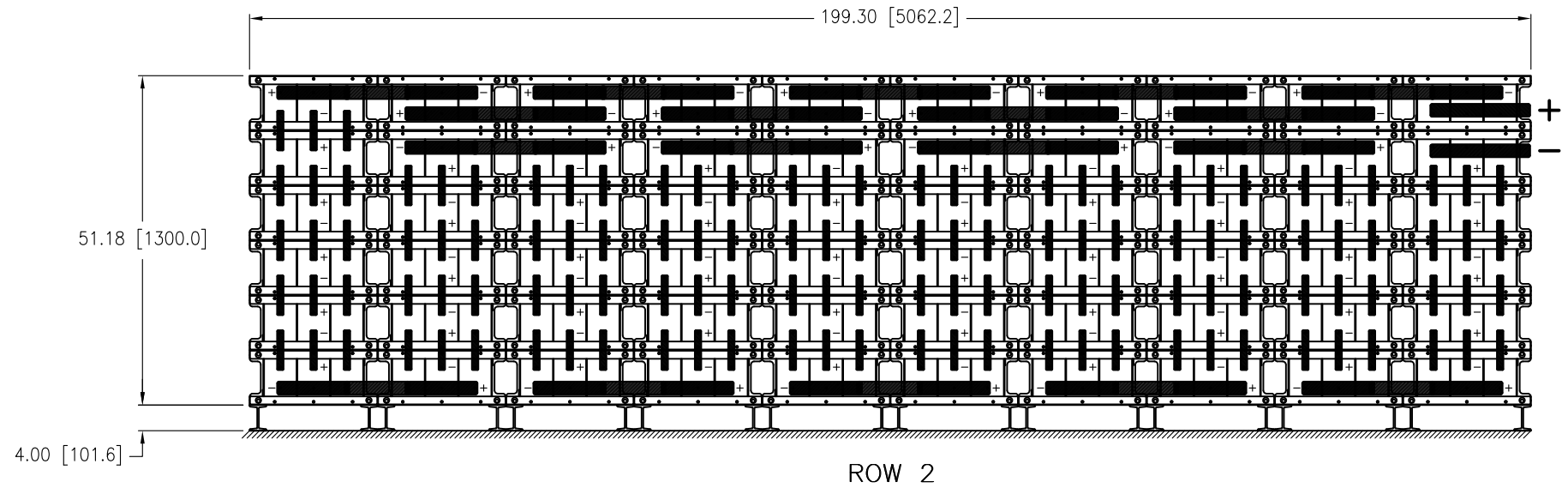
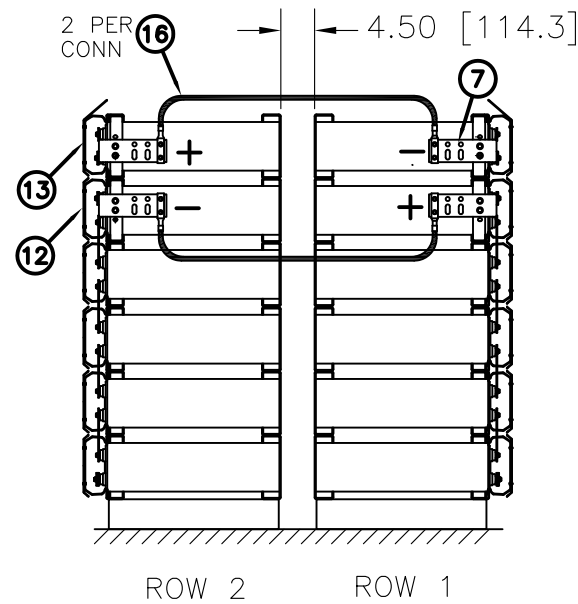
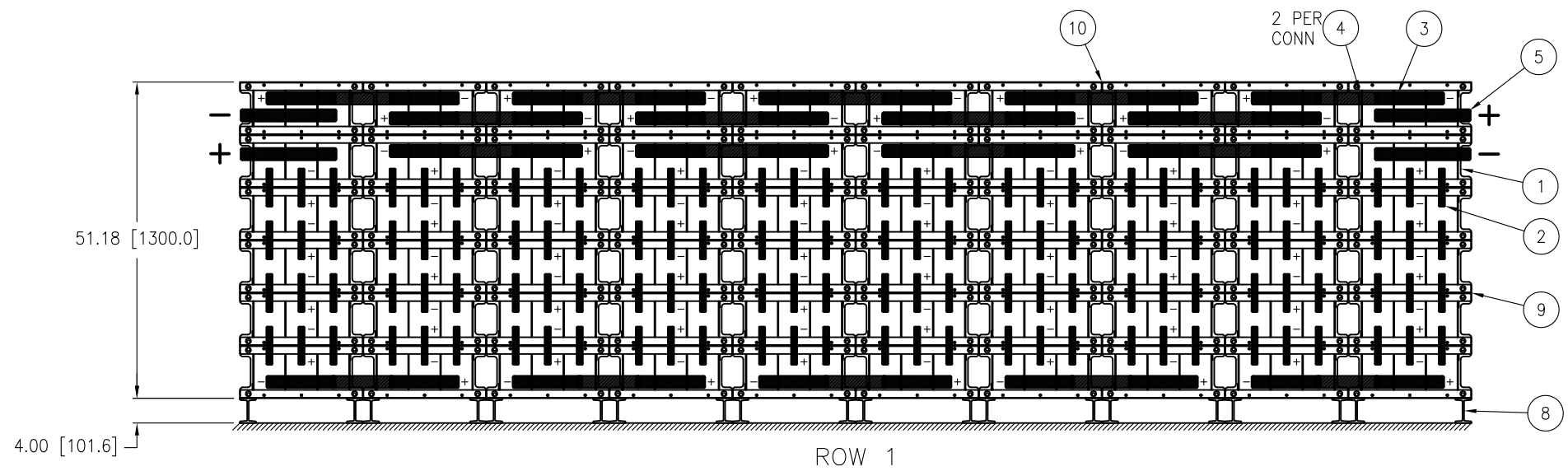

 GNB INDUSTRIAL POWER A Division of Exide Technologies	3950 SUSSEX AVENUE AURORA, IL 60504-7932 USA	CREATED WITH AC	SIZE	CAGE CODE	DRAWING NO.	REV
		B	88219	440429	0	
SCALE: 3/64			THIS DWG. SUPERCEDES		SHEET 2 OF 2	