

ESMART 4 Generation MPPT Solar Charge Control



EFS series solar charge controller is small and exquisite in appearance, based on MPPT controller algorithm design, can quickly track the maximum power point of photovoltaic array in any environment; support various lead-acid batteries, lithium batteries or other types of batteries, built-in various protection functions. The protection function can be widely used in various fields such as RVs, communication base stations, household systems and field monitoring systems.

Features

- ✓ The MPPT efficiency is $\geq 99.5\%$, and the conversion efficiency of the whole machine is as high as 98%.
- ✓ Built-in lithium battery activated wake-up function.
- ✓ A variety of battery (including lithium battery) charging can be customized.
- ✓ Support host computer and APP remote monitoring.
- ✓ RS485 bus, unified integrated management and secondary development.
- ✓ Ultra-quiet air-cooled design, more stable operation.
- ✓ A variety of protection functions, small body is very useful.

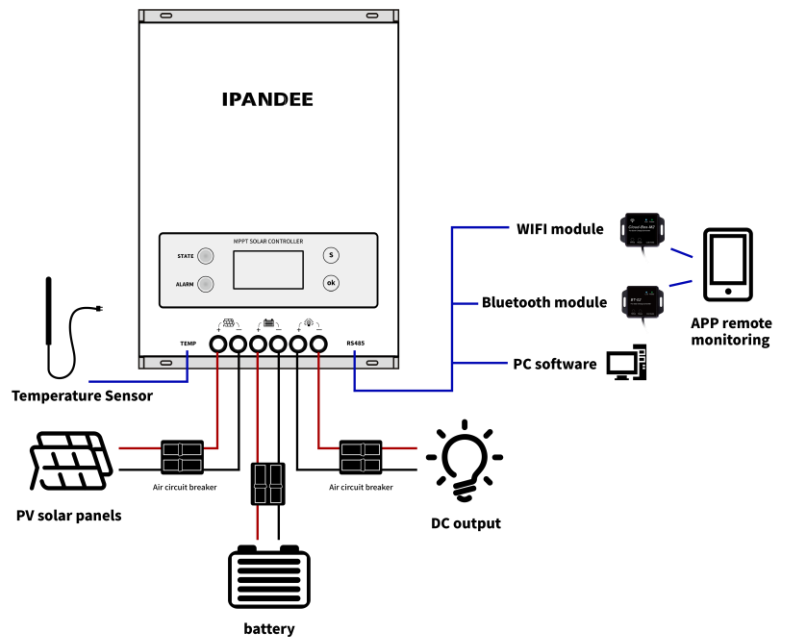

Application scenarios

Household power station system



Telecom base station



RV power supply



Solar monitoring



ESF Series MPPT Solar Charge Controller Specifications

		ESF48L50	ESF48L60	ESF48H50	ESF48H60	
Product Category	Controller type	Controller with Maximum Power Point Tracking (MPPT)				
	MPPT efficiency	≥99.5%				
	No-load static loss	0.5W~1.2W				
	system voltage	Auto				
	Cooling method	Fan cooling				
Input characteristics	PV Maximum Open Circuit Voltage (VOC)	150Vdc		200Vdc		
	Start charging voltage point	3V higher than battery voltage				
	Input low voltage protection point	2V higher than the current battery voltage				
	Input overvoltage protection point	150Vdc		200Vdc		
	Rated input power	12V system	650W	780W	650W	780W
		24V system	1300W	1560W	1300W	1560W
36V system		1950W	2340W	1950W	2340W	
48V system		2600W	3120W	2600W	3120W	
Charging characteristics	Applicable battery type	Lead-acid battery / Li-ion battery				
	Lithium battery activation function	Optional				
	Charge rated current	50A	60A	50A	60A	
	charging method	Lead-acid battery: fast charge, equal charge, floating charge; lithium battery: fast charge, equal charge				
Load characteristics	load voltage	same battery voltage				
	Rated load current	30A				
	Load control method	Normally open and normally closed mode/dual period control mode/light control mode/light control-fixed time control mode				
Display/Communication	Display method	High-definition LCD segment code backlight display				
	communication method	8-pin RJ45 interface/RS485/support host computer monitoring/support external Bluetooth, WIFI module expansion to realize app cloud monitoring/support external monitoring header				
other properties	Protective function	Input and output over-voltage protection, anti-reverse connection protection, battery drop protection, etc.				
	Working temperature	-20°C~+50°C				
	Storage temperature	-40°C~+75°C				
	IP protection class	IP21				
	Maximum wire size	20mm ²				
	Net weight (kg)	1962.7g				
	Gross weight (kg)					
	Product size (mm)	240*166*65				
Packaging size (mm)	299*203*70					

PSC SOLAR UK. ,

**41B OLUTOYE CRES. OFF ADENIYI JONES. IKEJA LAGOS
KM 38, LEKKI/EPE EXPRESS WAY. LAKOWE. LAGOS**

**Telephone: +234 812 085 5444 Mail: info@psc solaruk.com
or +234 808 955 2800**

URL: www.psc solaruk.com



FC RoHS CE